

HYOSUNG

HYOSUNG

HYOSUNG MOTORS & MACHINERY INC.

Comet 650 S

Comet 650 S
Comet 650 R

SERVICE MANUAL

SERVICE MANUAL

99000-94910

FOREWORD

This manual contains an introductory description on HYOSUNG 『Comet^{SS}』 & 『Comet^{SR}』 and procedures for its inspection/service and overhaul of its main components.

It covers the differences from 『Comet^{SS}』 and please refer to the service manual of 『Comet^{SS} (99000-94810)』 for others which are not covered in this manual.

This page numbers on the top are ones which are in the service manual of 『Comet^{SS}』 and ones on the bottom are the page numbers in this manual.

Other information considered as generally known is not included.

Read GENERAL INFORMATION section to familiarize yourself with outline of the vehicle and MAINTENANCE and other sections to use as a guide for proper inspection and service.

This manual will help you know the vehicle better so that you can assure your customers of your optimum and quick service.

- ❖ This manual has been prepared on the basis of the latest specification at the time of publication.
If modification has been made since then, difference may exist between the content of this manual and the actual vehicle.
- ❖ Illustrations in this manual are used to show the basic principles of operation and work procedures.
They may not represent the actual vehicle exactly in detail.

WARNING

This manual is intended for those who have enough knowledge and skills for servicing HYOSUNG vehicles. Without such knowledge and skills, you should not attempt servicing by relying on this manual only.
Instead, please contact your nearby authorized HYOSUNG motorcycle dealer.

GROUP INDEX

GENERAL INFORMATION

1

PERIODIC MAINTENANCE

2

ELECTRICAL SYSTEM

6

CHASSIS

7

SERVICING INFORMATION

8

 HYOSUNG MOTORS & MACHINERY INC.



Comet 650S (Standard type)



Comet 650S (Sports type)



Comet 650R

NOTE

Difference between photographs and actual motorcycles depends on the markets.

HOW TO USE THIS MANUAL





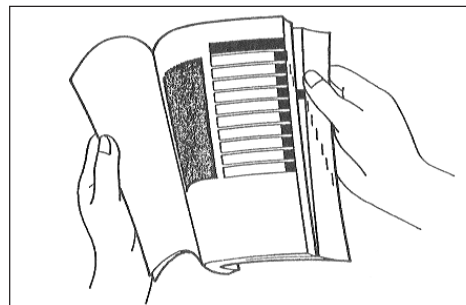









TO LOCATE WHAT YOU ARE LOOKING FOR:

1. The text of this manual is divided into sections.
2. As the title of these sections are listed on the previous page as GROUP INDEX, select the section where you are looking for.
3. Holding the manual as shown at the right will allow you to find the first page of the section easily.
4. On the first page of each section, its contents are listed. Find the item and page you need.



SYMBOL

Listed in the table below are the symbols indicating instructions and other information necessary for servicing and meaning associated with them respectively.

SYMBOL	DEFINITION	SYMBOL	DEFINITION
	Torque control required. Data beside it indicates specified torque.		Apply THREAD LOCK "1324".
	Apply oil. Use engine oil unless otherwise specified.		Apply or use brake fluid.
	Apply SUPER GREASE "A".		Measure in voltage range.
	Apply SUPER GREASE "C".		Measure in resistance range.
	Apply SILICONE GREASE.		Measure in current range.
	Apply MOLY PASTE.		Use special tool.
	Apply BOND "1215".		Use engine coolant.
	Use fork oil.		

GENERAL INFORMATION

1

CONTENTS

<i>EXTERIOR ILLUSTRATION</i>	6 (1-7-1)
<i>SPECIFICATIONS</i>	9 (1-8)

1-7-1 GENERAL INFORMATION

EXTERIOR ILLUSTRATION [*Comet 650S* (Standard type)]

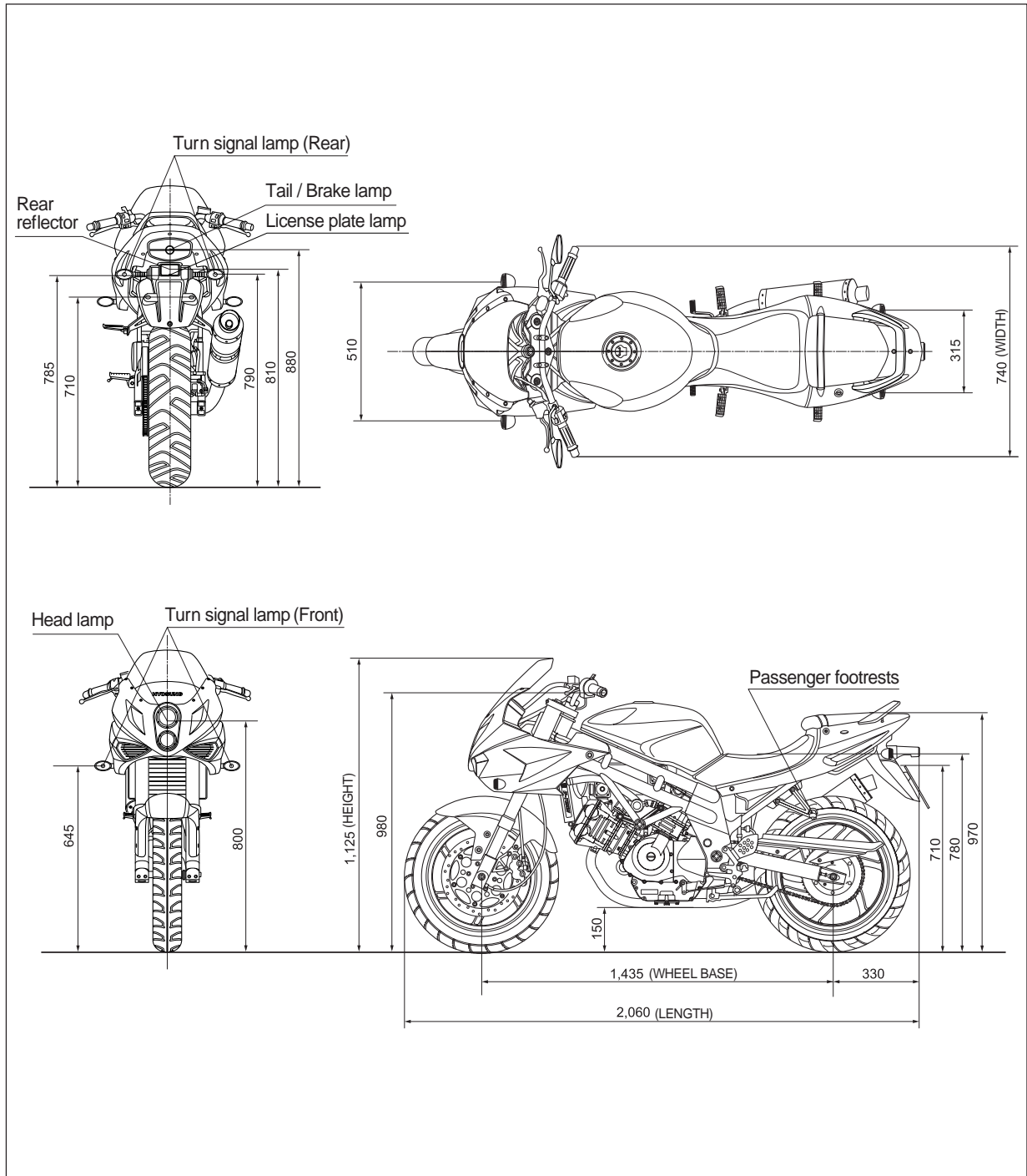

EXTERIOR ILLUSTRATION [*Comet 650S* (Sports type)]

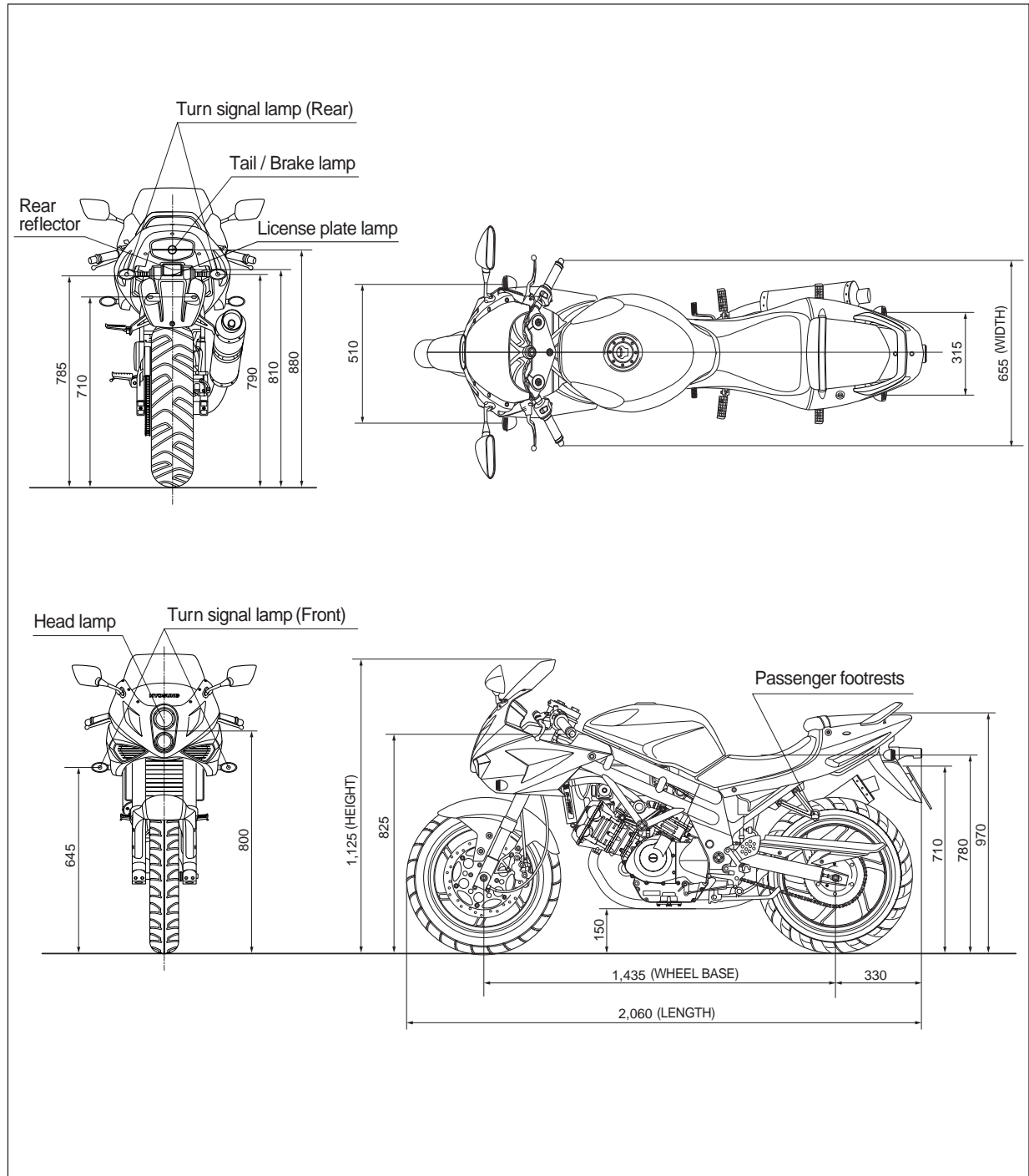

1-7-3 GENERAL INFORMATION

EXTERIOR ILLUSTRATION [*Comet 650R*]

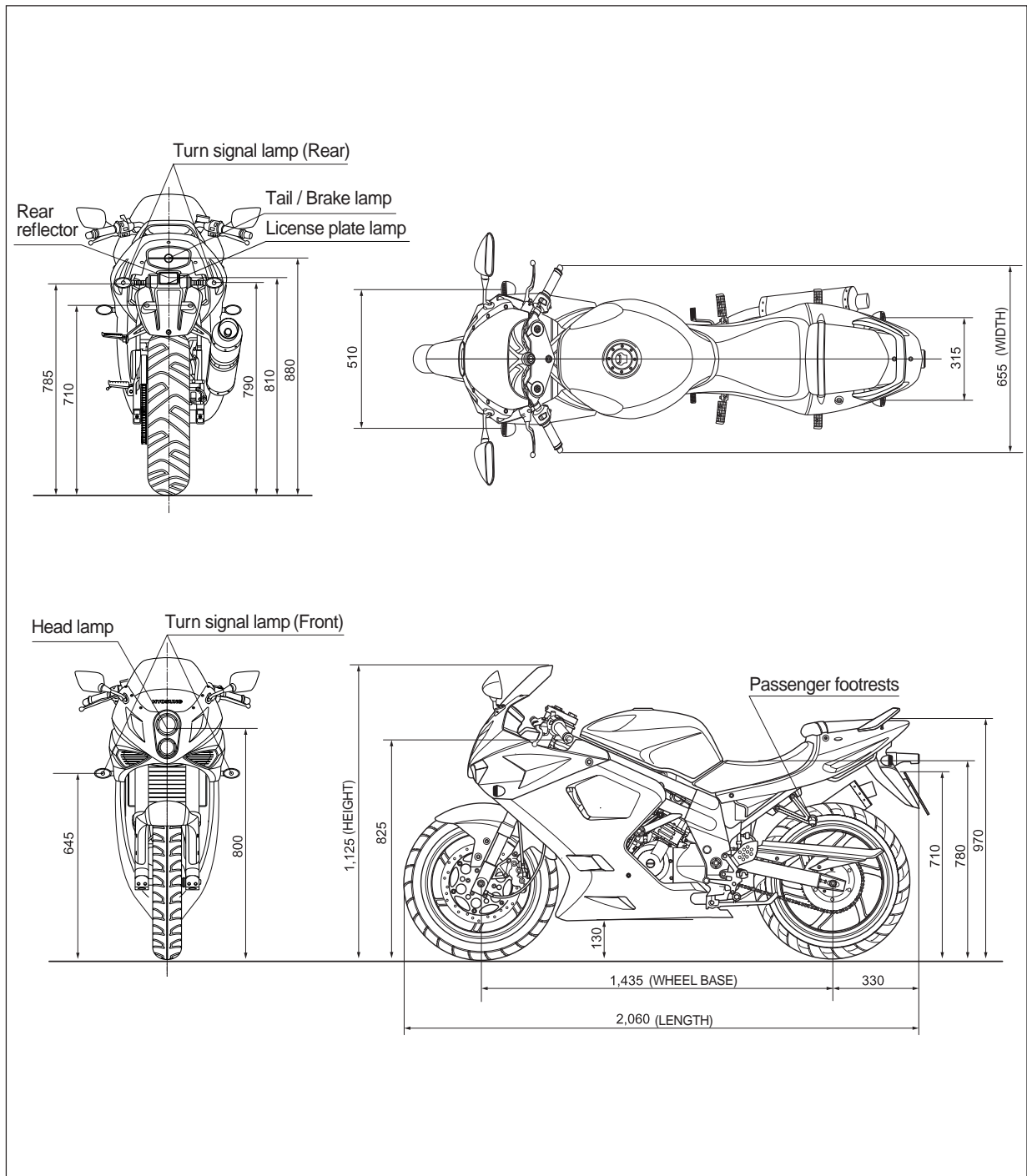

SPECIFICATIONS

DIMENSIONS AND DRY MASS

ITEM	<i>Comet 650 S</i> (Standard type)	<i>Comet 650 S</i> (Sport type)	<i>Comet 650 R</i>
Overall length	2,060 mm (81.1 in)	←	←
Overall width	740 mm (29.1 in)	655 mm (25.8 in)	←
Overall height	1,125 mm (44.3 in)	←	←
Wheelbase	1,435 mm (56.5 in)	←	←
Ground clearance	150 mm (5.9 in)	←	130 mm (5.1 in)
Mass	215 kg (474 lbs)	←	220 kg (485 lbs)

ENGINE

ITEM	<i>Comet 650 S</i> (Standard type)	<i>Comet 650 S</i> (Sport type)	<i>Comet 650 R</i>
Type	Four-stroke, DOHC, Liquid-cooled	←	←
Number of cylinder	V-2 cylinder	←	←
Bore	81.5 mm (3.21 in)	←	←
Stroke	62.0 mm (2.44 in)	←	←
Piston displacement	647 cm ³ (39.5 in ³)	←	←
Carburetor	BDSR39 TYPE (DOUBLE)	←	←
Starter system	Electric starter	←	←
Lubrication system	Wet sump	←	←

TRANSMISSION

ITEM	<i>Comet 650 S</i> (Standard type)	<i>Comet 650 S</i> (Sport type)	<i>Comet 650 R</i>
Clutch	Wet multi-plate type	←	←
Transmission	6-speed constant mesh	←	←
Gearshift pattern	1-down, 5-up	←	←
Final reduction	2.93	←	←
Gear ratio, 1st	2.46	←	←
2nd	1.60	←	←
3rd	1.32	←	←
4th	1.13	←	←
5th	0.96	←	←
6th	0.85	←	←
Drive chain	RK525XS0 108 links	←	←

1-9 GENERAL INFORMATION

CHASSIS

ITEM	<i>Comet650S</i> (Standard type)	<i>Comet650S</i> (Sport type)	<i>Comet650R</i>
Front suspension	Telescopic type	←	←
Rear suspension	Swingarm type	←	←
Steering angle	27 ° (right & left)	←	←
Caster	25.5 °	←	←
Trail	74 mm (2.91 in)	←	←
Front brake	Double disk brake	←	←
Rear brake	Disk brake	←	←
Front tire size	120/60 - ZR 17 55W	←	←
Rear tire size	160/60 - ZR 17 69W	←	←
Front fork stroke	120 mm (4.72 in)	←	←

ELECTRICAL

ITEM	<i>Comet650S</i> (Standard type)	<i>Comet650S</i> (Sport type)	<i>Comet650R</i>
Ignition type	"Igniter" type	←	←
Ignition timing	5 ° B.T.D.C.at 1,500 rpm	←	←
Spark plug	CR8E	←	←
Battery	12V 12Ah (MF)	←	←
Fuse	Main	30 A	←
	Head lamp	15 A	←
Head lamp	HI	12V - H1 : 55W × 1	←
	LO	12V - H3 : 55W × 1	←
Turn signal lamp	12V - 10W × 4	←	←
Brake / Tail lamp	12V - 21/5W × 1	←	←
Illumination lamp	12V - 1.7W × 2	←	←
License plate lamp	12V - 5W × 1	←	←
High beam indicator lamp	VFD	←	←
Turn signal indicator lamp(right & left)	VFD	←	←
Neutral indicator lamp	VFD	←	←
Fuel indicator lamp	VFD (Level type)	←	←
Coolant temperature indicator lamp	VFD (Level type)	←	←

CAPACITIES

ITEM	<i>Comet650S</i> (Standard type)	<i>Comet650S</i> (Sport type)	<i>Comet650R</i>
Fuel tank	17.0 l	←	←
Engine oil, oil change	3,000 ml	←	←
with filter change	3,200 ml	←	←
overhaul	3,400 ml	←	←
Front fork oil capacity(One side)	380 cc	←	←

NOTE

The specifications are subject to change without notice.

PERIODIC MAINTENANCE

CONTENTS

MAINTENANCE PROCEDURES

<i>CARBURETOR</i>	12 (2-7)
<i>CLUTCH</i>	13 (2-9-1)
<i>ENGINE COOLANT</i>	16 (2-20)

2

MAINTENANCE PROCEDURES

CARBURETOR

Inspect Interval

Inspect Initial 1,000 km and Every 6,000 km.

⌚ IDLE SPEED

NOTE

Make this inspection when the engine is hot.

- Connect an engine tachometer to the high tension cord.
Start up the engine and set its speed at anywhere 1,300 and 1,500 rpm by turning throttle stop screw ①.

Engine idle speed	1,300 ~ 1,500 rpm
--------------------------	-------------------

 Engine tachometer : 09900-26006

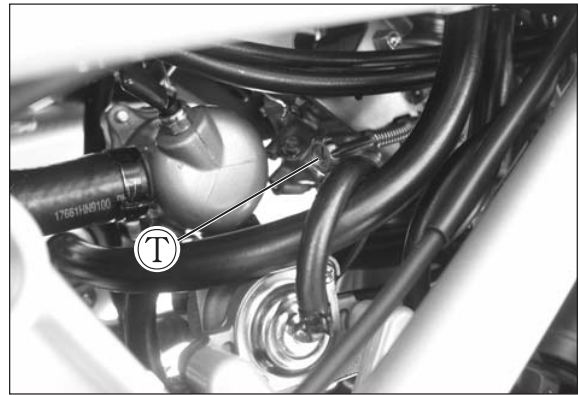

『 Comet 650 S 』



『 Comet 650 R 』

CLUTCH

Inspect Interval

Inspect Initial 1,000 km and Every 6,000 km.

Clutch play should be 2 mm(0.08 in) as measured at the clutch lever holder before the clutch begins to disengage. If the play in the clutch is incorrect, adjust it in the following way :

- A basis adjustment can be done by the clutch lever adjuster ②.
- Loosen the clutch lever adjuster ②.
- Screw the lock nut ① clockwise fully, after finishing adjustment.
- After finishing adjustment, tighten the lock nut ① and cover the rubber boot ⑤.
- If it is not adjusted by the adjuster ②, loosen the clutch cable adjuster lock nut ③.
- Turn the clutch cable adjuster ④ in or out to acquire the specified play.
- After finishing adjustment, tighten the lock nut ③.
- The clutch cable should be lubricated with a light weight oil whenever it is adjusted.

Clutch cable play ㊦	2 mm (0.08 in)
---------------------	----------------

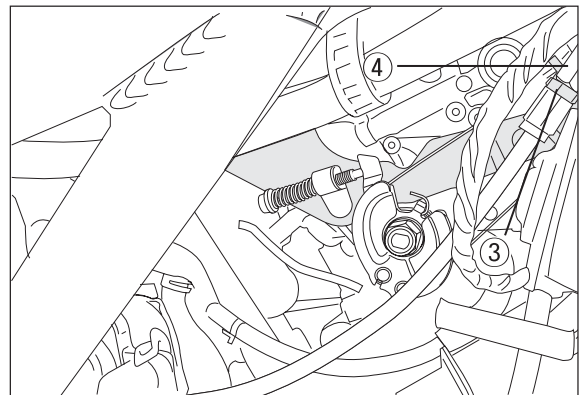
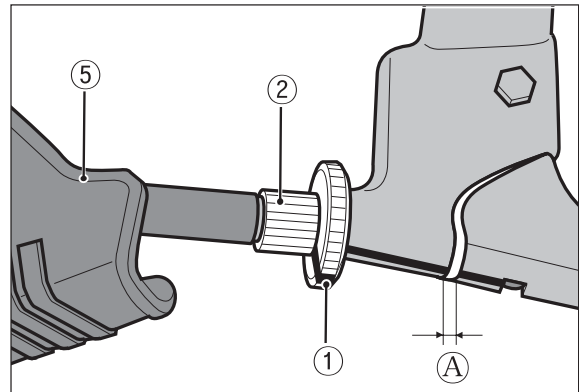

『Comet 650S (Standard type)』

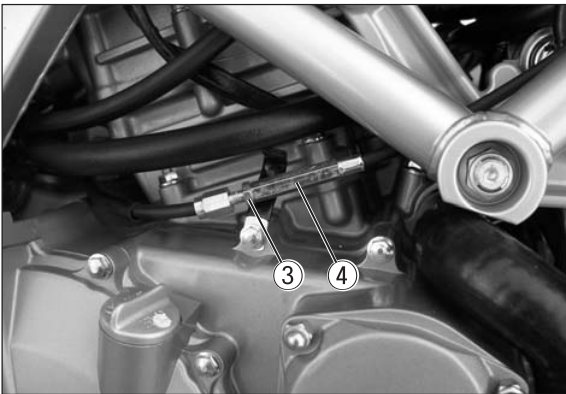

『Comet 650S (Sports type)』

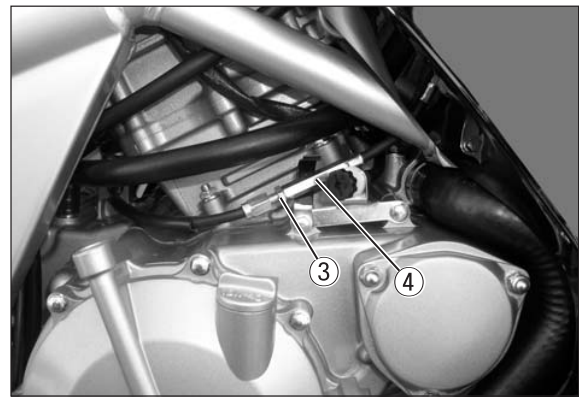

『Comet 650R』

㊦ GEARSHIFT LEVER HEIGHT ADJUSTMENT

- Loosen the lock nut ⑥.
- With the link rod ⑦ turned, adjust the gearshift lever height.
- Tighten the lock nut ⑥.

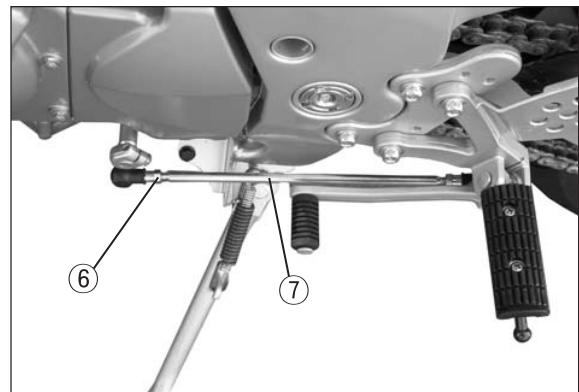

FOOTREST POSITION ADJUSTMENT

『Comet650S』 & 『Comet650R』 have 3 type of the footrest position, right and left.

To change the position, remove the 8mm wrench bolts ①, ② and install the bolts to the desired position by using the hexagon wrench 6mm.

『Comet650S』 & 『Comet650R』 are delivered from the factory on position ①.

⚠ WARNING

When adjusting the footrest position, the 8mm wrench bolts be torqued to the proper specification.
If they are not, the footrest can come off unexpectedly.

 Footrest mounting bolt
: 22 ~ 35 N·m (2.2 ~ 3.5 kgf·m)

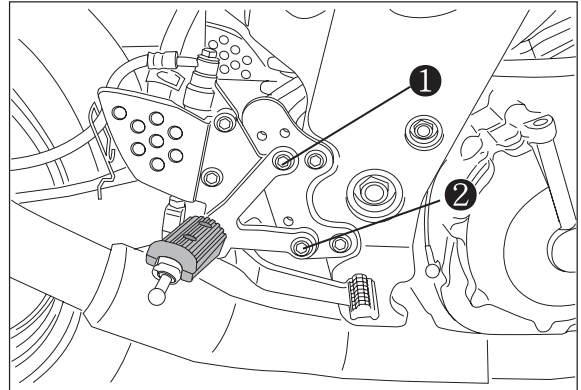

[POSITION ①]

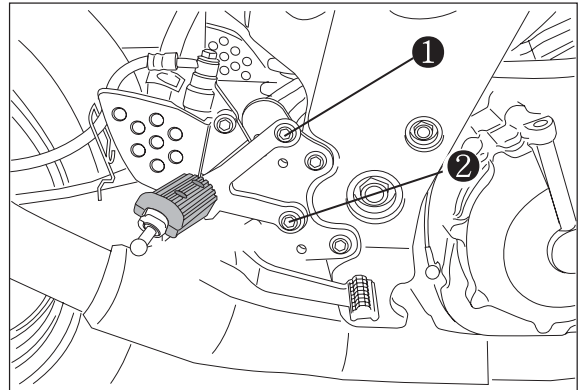

[POSITION ②]

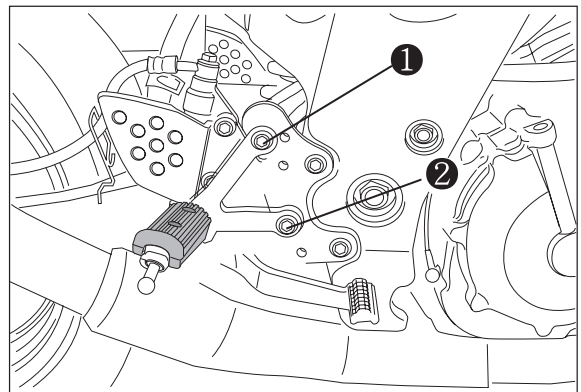

[POSITION ③]

Ⓒ GEARSHIFT LINK ROD

(FOR: 『 Comet 650 S 』 & 『 Comet 650 R 』 > S
OPTIONAL PARTS)

When the footrests in position Ⓒ, exchange the gearshift link rod for appropriate riding position.

- Position Ⓐ or Ⓑ
: Install the gearshift link rod ③
- Position Ⓒ
: Install the gearshift link rod ④

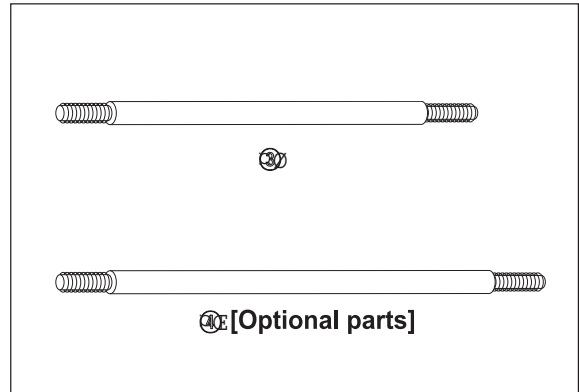

NOTE

The gearshift link rod ④ is optional parts.

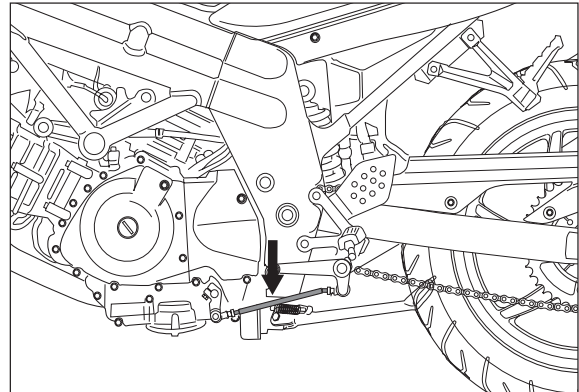

ENGINE COOLANT

⦿ SIDE COWLING INNER

『Comet650S』 & 『Comet650R』 have the “side cowl inner” ① at the rightside.

Use the “side cowl inner” to operate the radiator cap ③.

To disassemble the “side cowl inner”, remove the two screws ②.

WARNING

Do not open the radiator cap when the engine is hot, as you may be injured by escaping hot liquid or vapor.

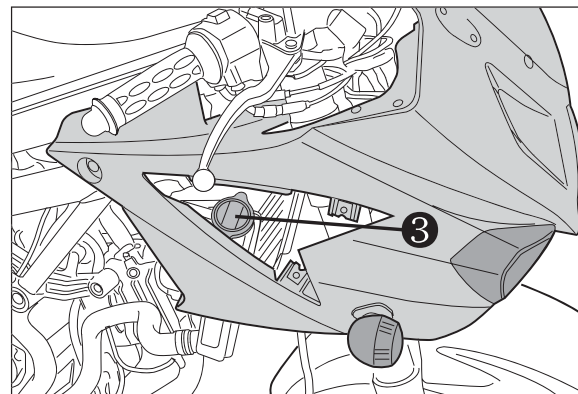
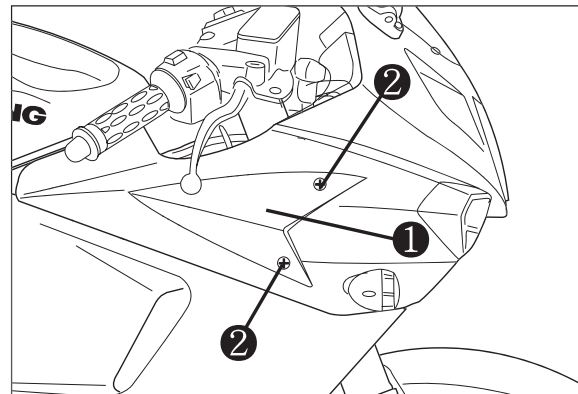

『Comet650S』

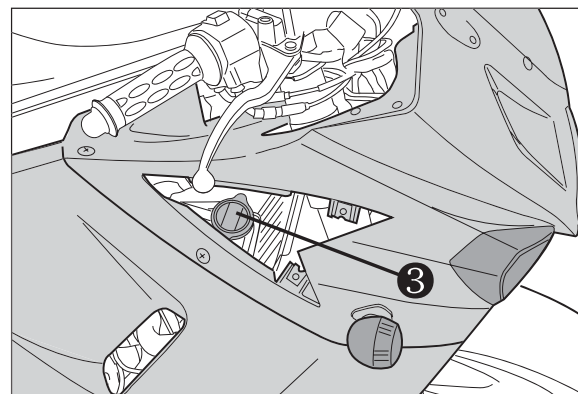

『Comet650R』

ELECTRICAL SYSTEM

CONTENTS

IGNITION SYSTEM	18 (6-6)
LAMP	19 (6-16-1)

6

IGNITION SYSTEM

■ IGNITER

Using the pocket tester(R × 1kΩ range), measure the resistance between the terminal in the following table.

⚠ CAUTION

- ❖ Numerical value may differ a little according to the tester.
- ❖ Please remind that there may be a defect which can not be identified even though the measurement by using the tester indicates a low voltage.
- ❖ The range of measurement adjust a [X 1kΩ] unit.

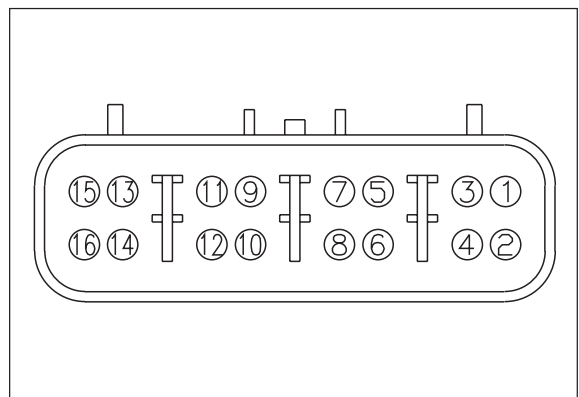
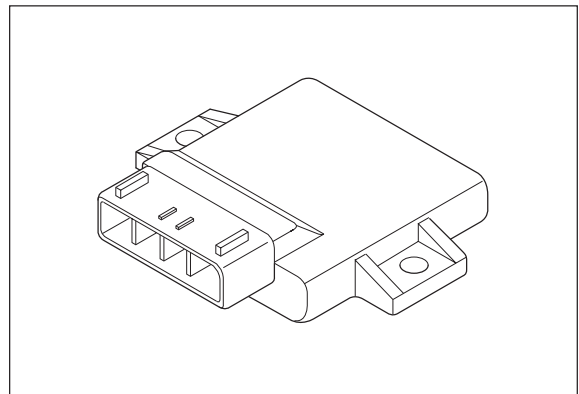

Pocket Tester : 09900-25002

Unit : kΩ

⊕ TESTER PROBE																	
	①	②	③	④	⑤	⑥	⑦	⑧	⑨	⑩	⑪	⑫	⑬	⑭	⑮	⑯	
TESTER PROBE	①	OFF	OFF	OFF	OFF	OFF	OFF	OFF	OFF	OFF	OFF	OFF	OFF	OFF	OFF	OFF	
	②	OFF	OFF	OFF	OFF	OFF	OFF	OFF	OFF	OFF	OFF	OFF	OFF	OFF	OFF	OFF	
	③	250-370	250-380	OFF	OFF	OFF	9.2-13.8	37-55	23.6-35.4	21.6-32.4	22.4-33.6	18-27	53-79	29.5-44.5	9.2-13.8	21.3-31.9	
	④	180-270	180-270	2.9-4.4	OFF	OFF	8.4-12.6	9.6-14	3.8-5.8	2.7-4.1	3-4.6	0	46-69	6.4-9.6	7.1-10.4	2.2-3.4	
	⑤	180-270	180-270	9.6-14	2.8-4.2	OFF	9.6-14	12.2-18.2	2.6-4	1.4-2	1.8-2.6	2.8-4.2	49-73	9.1-13.7	8.6-13	0.9-1.3	
	⑥	OFF	OFF	OFF	OFF	OFF	OFF	OFF	OFF	OFF	OFF	OFF	OFF	OFF	OFF	OFF	
	⑦	200-300	210-310	21.5-32.5	11.1-16.7	14.3-21.5	OFF	OFF	25.7-38.5	15.4-23	14.2-21.2	14.6-21.8	11.2-16.8	39-59	20.4-30.6	4.7-7.1	13.7-20.5
	⑧	OFF	OFF	OFF	OFF	OFF	OFF	OFF	OFF	OFF	OFF	OFF	OFF	OFF	OFF	OFF	
	⑨	180-270	190-280	11-16.4	3.8-5.7	2.6-4	OFF	10.8-16.2	13.6-20.4	OFF	2.4-3.6	0.9-1.3	3.9-5.9	50.5-75.5	10.4-15.6	9.6-14	1.8-2.8
	⑩	180-270	190-280	9.6-14	2.5-3.8	1.4-2	OFF	8.7-13.1	12-18	2.4-3.6	OFF	1.4-2	2.6-3.8	48-72	8.8-13.2	8-12	0.6-0.8
	⑪	180-270	180-270	10-15	3.1-4.7	1.7-2.5	OFF	9.6-14	12.5-18.7	0.9-1.3	1.5-2.3	OFF	3.1-4.7	49.5-74.5	9.6-14	8.8-13.2	1-1.4
	⑫	170-260	180-270	7-10.4	0	2.8-4.2	OFF	8.5-12.7	9.6-14	3.9-5.9	2.6-4	3-4.6	OFF	46.5-69.5	6.4-9.6	7.2-10.8	2.3-3.5
	⑬	330-490	330-500	180-270	150-230	80-120	OFF	170-250	190-280	150-230	150-230	150-230	150-230	OFF	170-260	165-245	146-219
	⑭	200-300	180-270	17.5-26.5	8.6-12.8	7.3-10.9	OFF	17.5-26.5	21.2-31.8	8.2-12.4	7-10.6	7.3-10.9	8.6-12.8	69-103	OFF	16.3-24.5	6.4-9.6
	⑮	200-300	210-310	16.5-24.5	7.4-11	10-15	OFF	4.6-7	20.8-31.2	11.4-17	10-15	10.4-15.6	7.3-10.9	34-51	15.6-23.4	OFF	9.6-14
	⑯	170-260	180-270	9-13.5	2.3-3.5	0.9-1.3	OFF	8.8-13.2	11.4-17	1.8-2.8	0.6-1	0.9-1.3	2.3-3.5	48-72	8.6-13	8.1-12.1	OFF

LAMP

⊕ HEAD LAMP

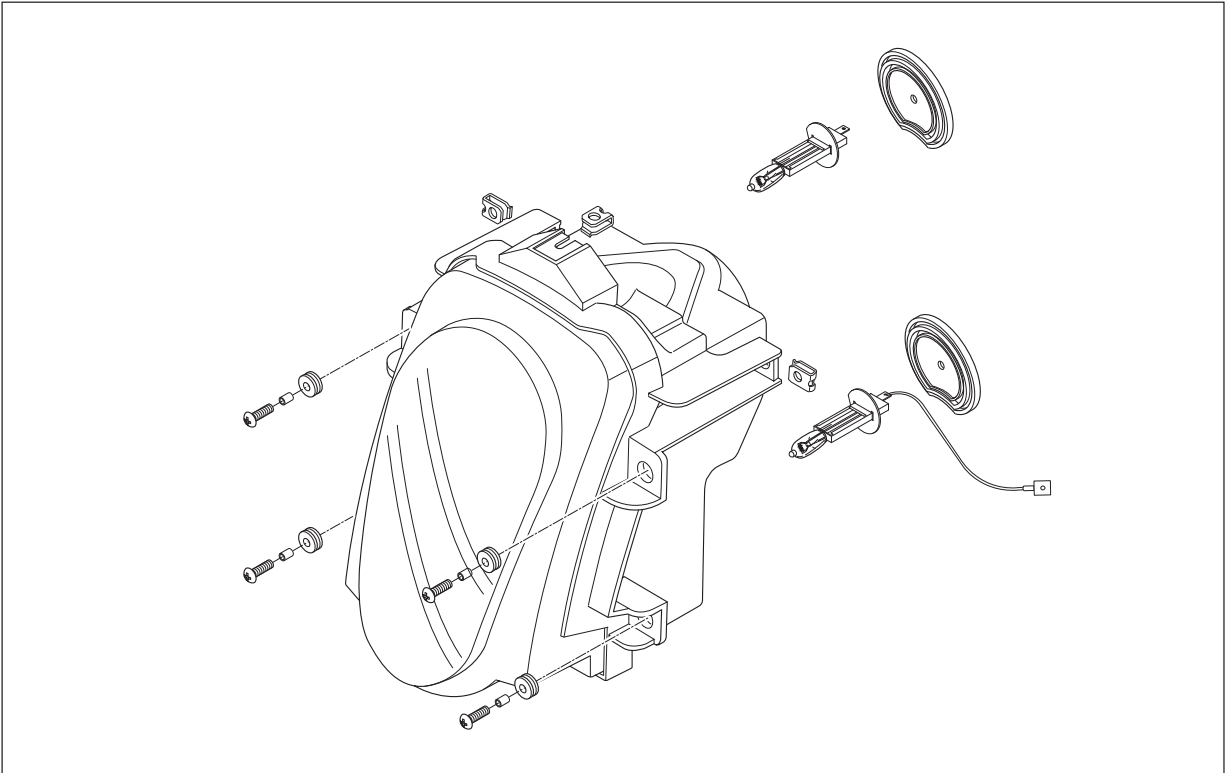

■ REPLACEMENT OF HEAD LAMP BULB

- Remove the under cowling. (*Comet 650R*)
(Refer to page 7-1-2 ~ 3)
- Remove the body cowling.
(Refer to page 7-1-4 ~ 5)
- Remove the head lamp coupler ①, ②.

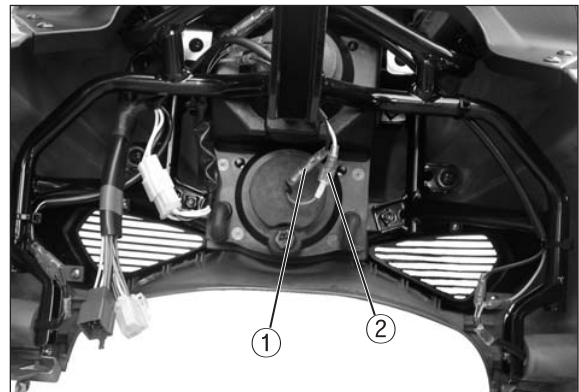

- Remove the dust cover ③.

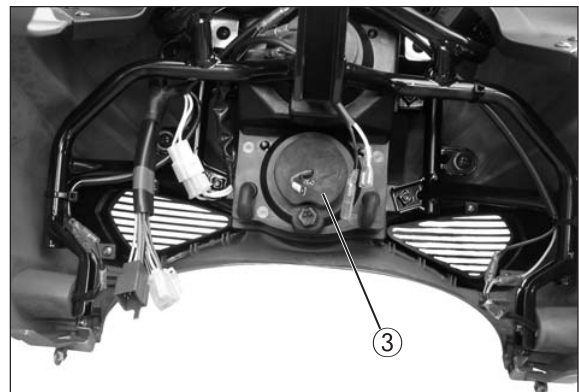

- Remove the socket spring ①.

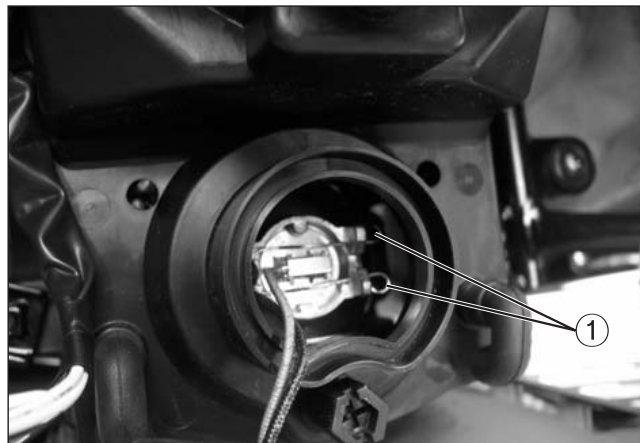

- Remove the bulb ② and replace the new bulb.

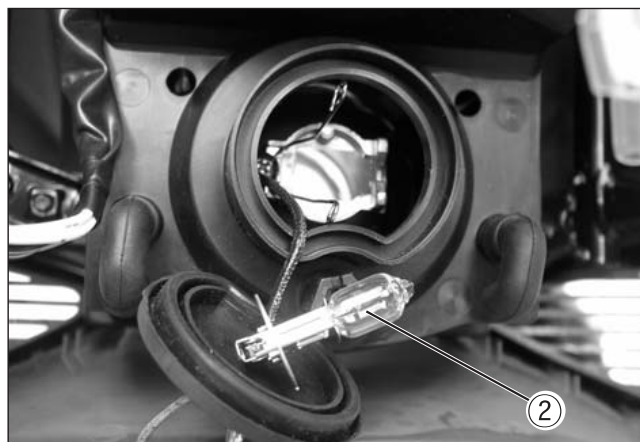

- Remove the head lamp "HI" bulb with the same manner of the head lamp "LOW" bulb removal.
- Reinstall the head lamp bulb in the reverse order of head lamp bulb removal.

⊙ COMBINATION METER

Remove the combination meter.

Disassemble the combination meter as shown in the illustration.

■ INSPECTION

Using the pocket tester, check the continuity between lead wires in the following illustration.

If the continuity measured incorrect, replace the respective part.

 Pocket tester : 09900-25002

CAUTION

When making this test, it is not necessary to remove the combination meter.

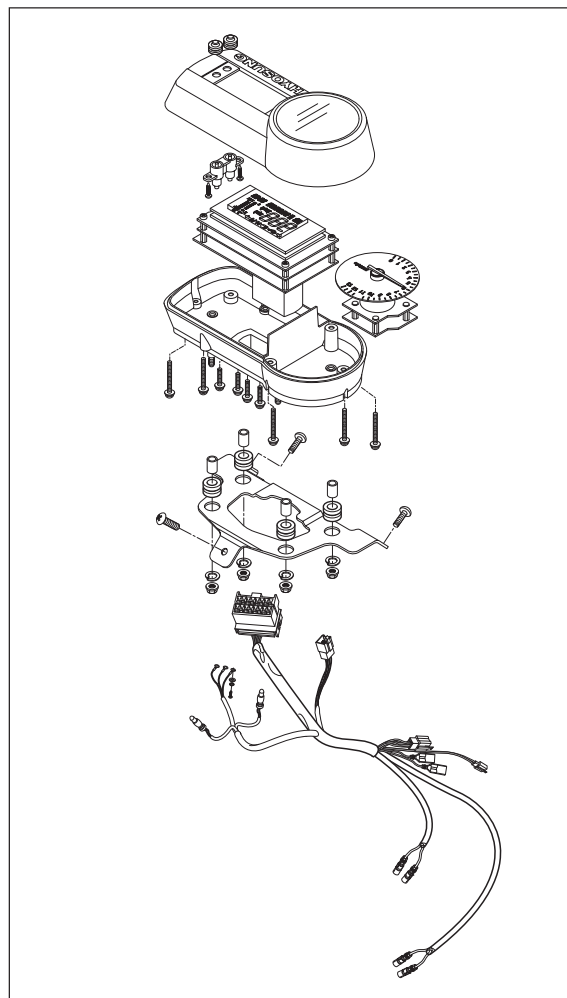

6-17-2 ELECTRICAL SYSTEM

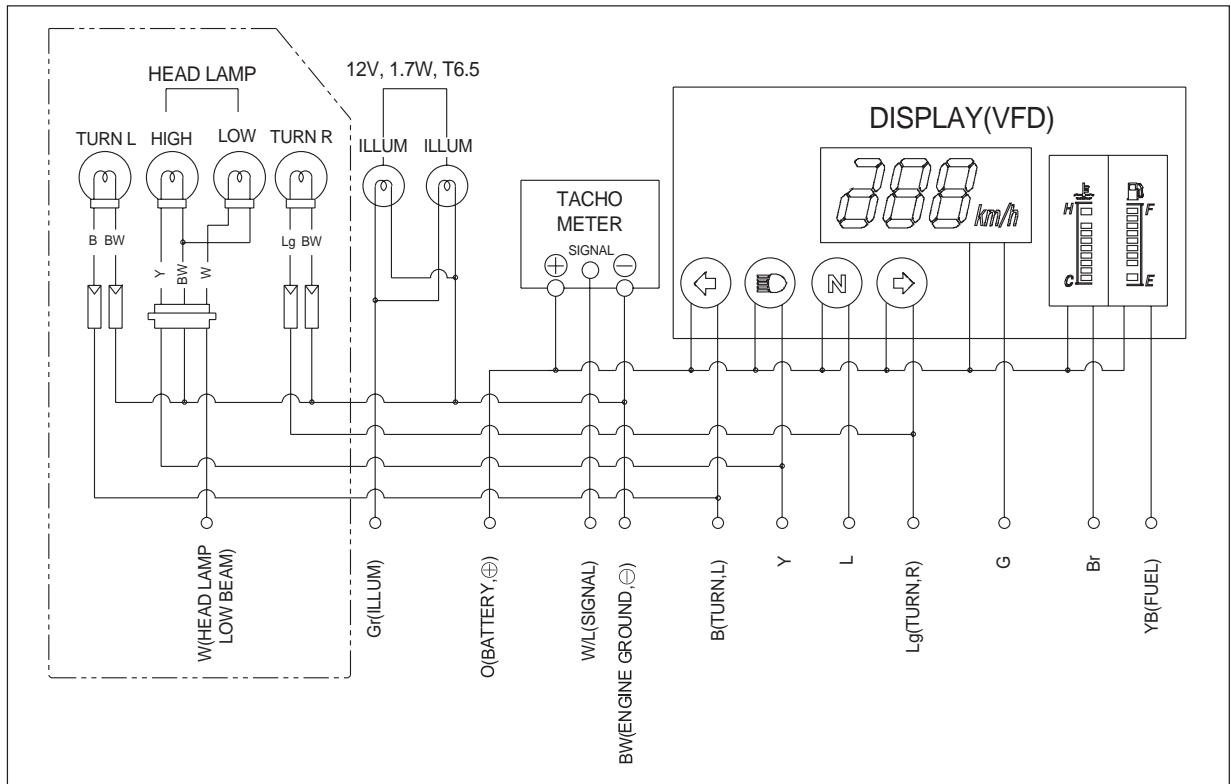

CHASSIS

CONTENTS

EXTERIOR PARTS	24 (7-1-1)
HANDLEBARS	29 (7-13-1)
STEERING	33 (7-23)

EXTERIOR PARTS

🔑 REAR CARRIER

■ REMOVAL

- Open the rear seat with the ignition key.



- Remove the rear carrier mounting bolts ① and separate the rear carrier ②.



■ INSTALLATION

Reassemble the rear carrier in the reverse order of removal.

- To reinstall the rear seat, slide the seat hook into the seat hook retainer and push down firmly until the seat snaps into the locked position.



⊕ UNDER COWLING (Only: *Comet 650 R*)

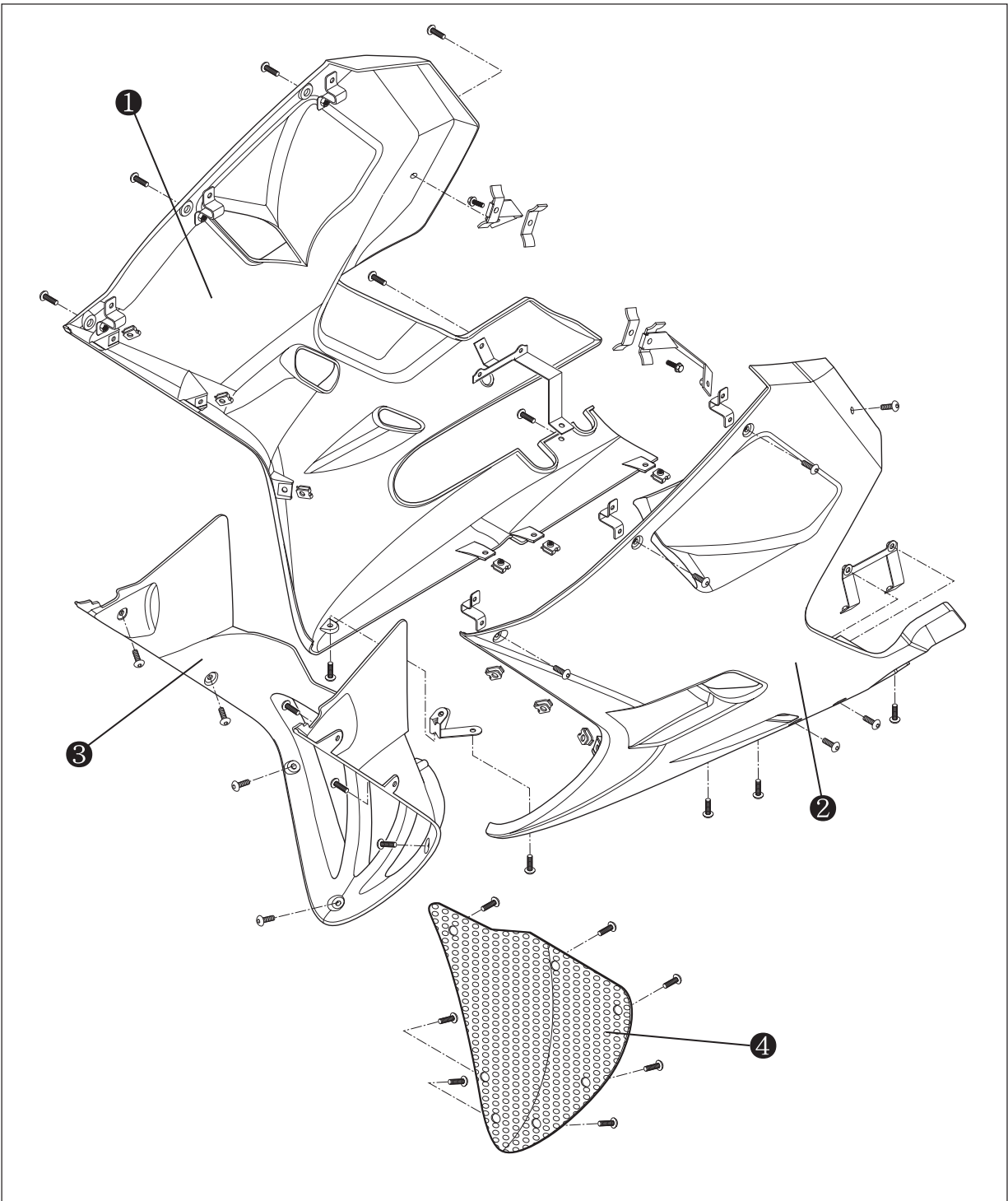

- ① Under cowling RH
- ② Under cowling LH

- ③ Under center cowling
- ④ Under center cowling grill

7-1-3 CHASSIS

■ REMOVAL

- Remove the under cowling screws at the rightside.

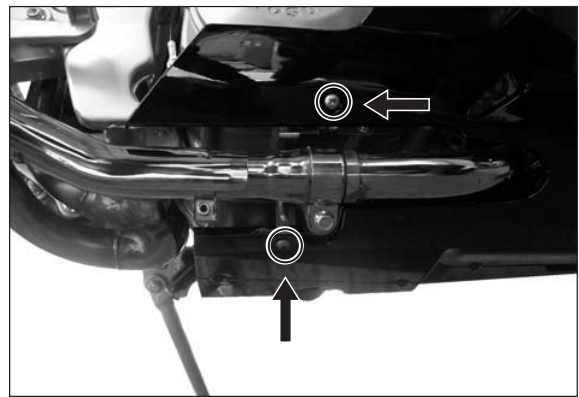
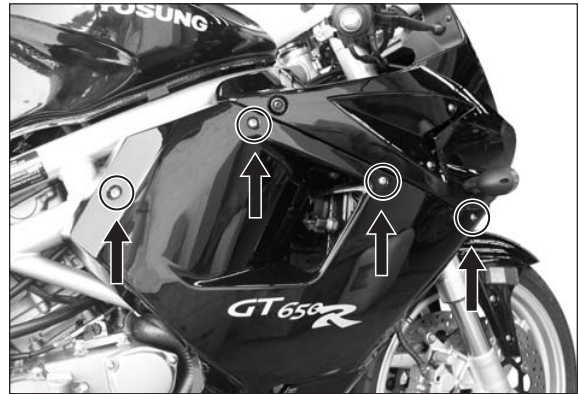

- Remove the under cowling screws at the leftside.

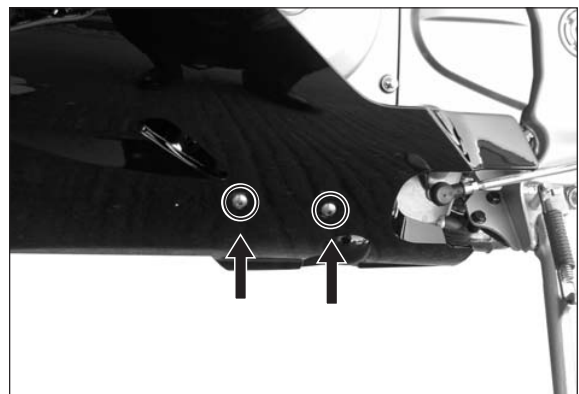
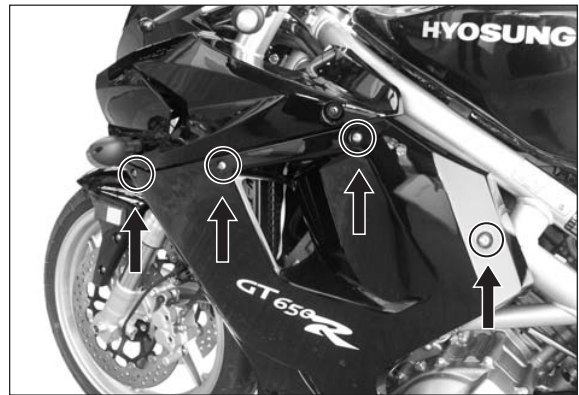

◎ BODY COWLING

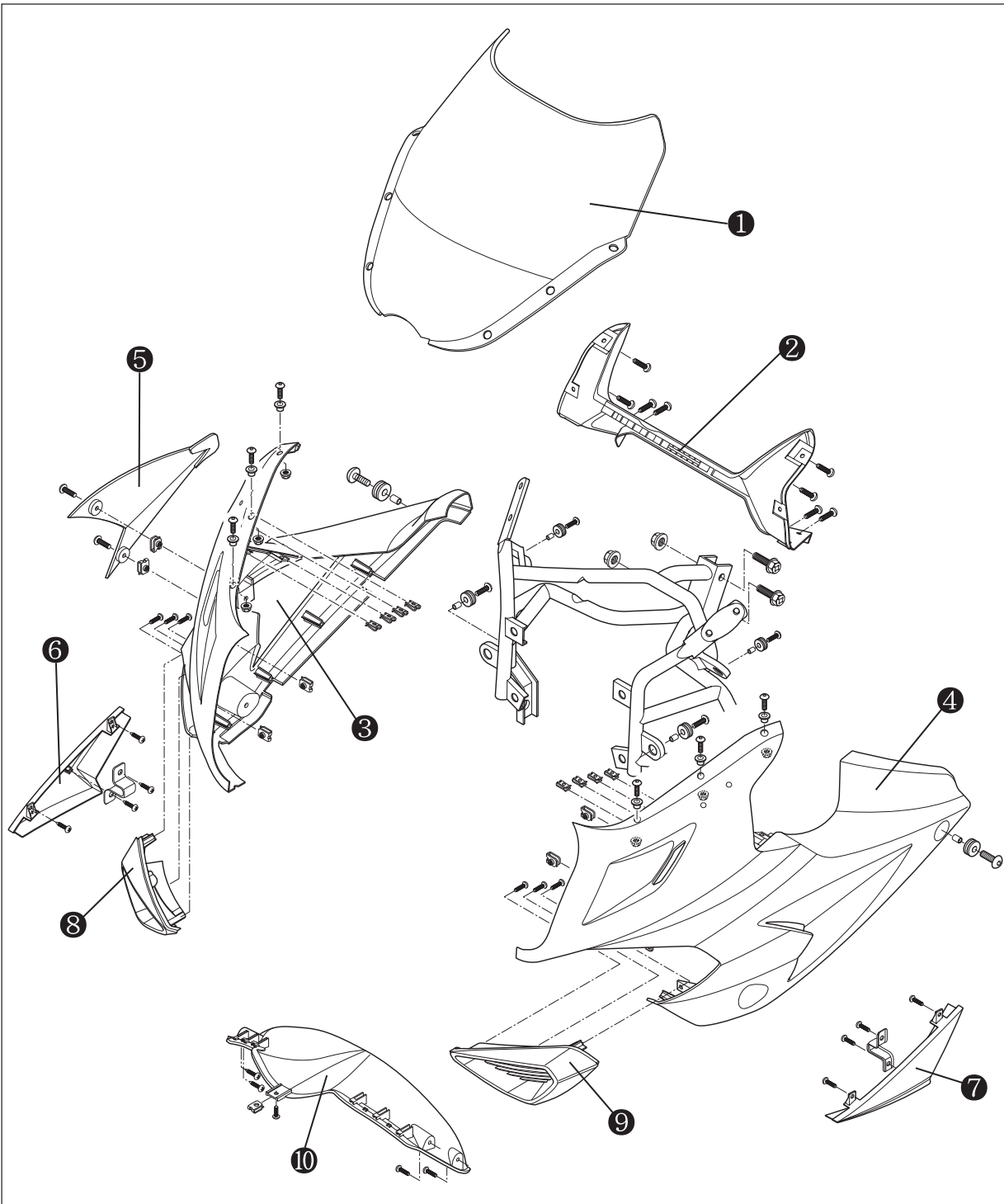

- | | | |
|--------------------------|--------------------------------|-----------------------------|
| □ Windscreen | □ ° Body side cowling inner RH | □ Air duct cowling LH |
| □ ⚓ Meter panel | □ Body side cowling lower RH | □ Body center lower cowling |
| □ ∅ Body side cowling RH | □ Body side cowling lower LH | |
| □ Ⓢ Body side cowling LH | □ Air duct cowling RH | |

7-1-5 CHASSIS

REMOVAL

- Remove the body cowling screw at the rightside.



- Remove the body cowling screw at the leftside.



- Remove the two cowling brace bolts.
- Remove the speedometer lead wire and head lamp lead wire.

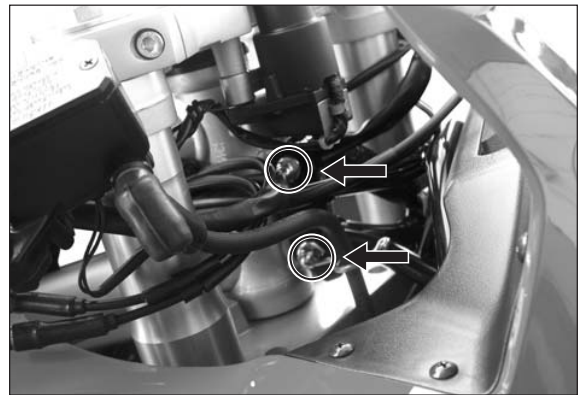

REMOUNTING

- Tighten the two cowling brace bolts.

- ☑ Cowling brace bolt
: 22 ~ 35 N·m (2.2 ~ 3.5 kg·m)

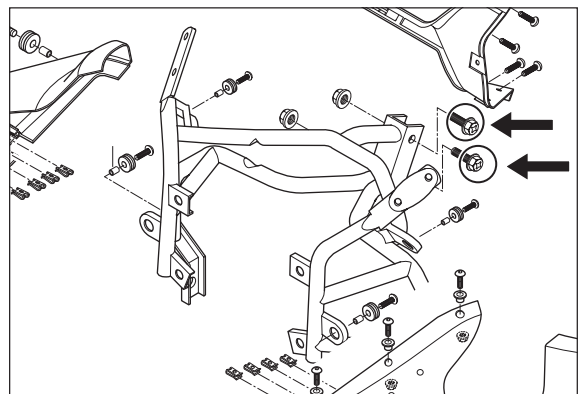

HANDLEBARS

⑤ *Comet650S* (Standad type)

☞ Refer to the service manual 『*Comet650* (99000-94810)』 page 7-13 ~ 14

⑤ *Comet650S* (Sports type) & *Comet650R*

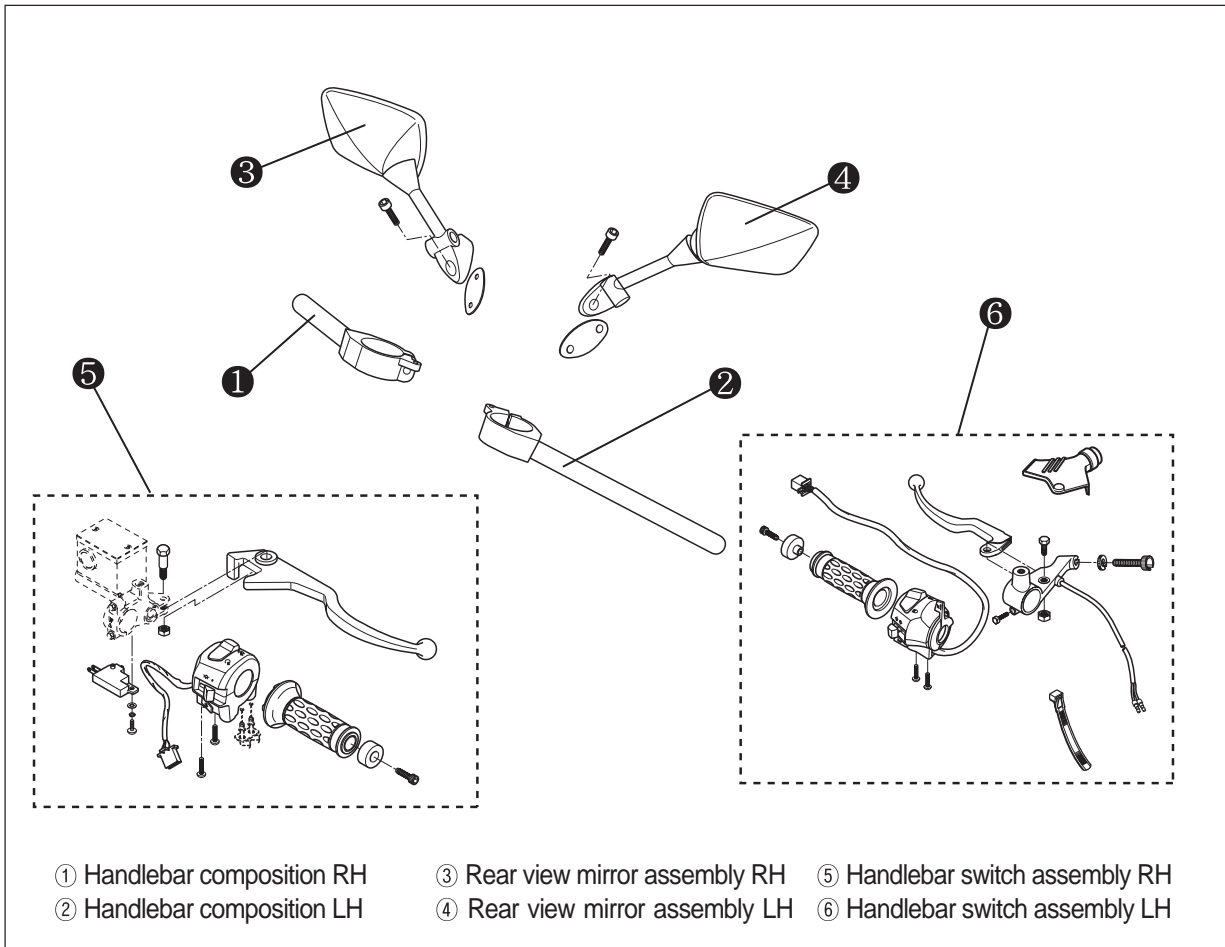

🔧 HANDLEBAR RIGHT SIDE PARTS REMOVAL

- Remove the right handlebar switches.
- Disconnect the brake lamp switch lead wires and remove the master cylinder.
 - ☞ Refer to the service manual 『*Comet650* (99000-94810)』 page 7-10
- Remove the handlebar balancer ⑦ and grip ⑧.

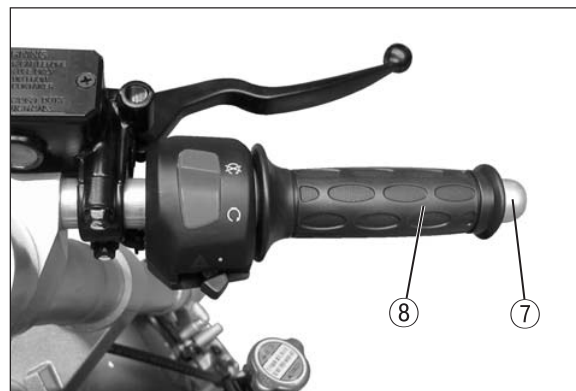

HANDLEBAR LEFT SIDE PARTS REMOVAL

- Remove the left handlebar switches.
- Remove the handlebar balancer ① and grip ②.
- Remove the clutch lever holder.



- Loosen the handlebar clamp bolts, right and left.

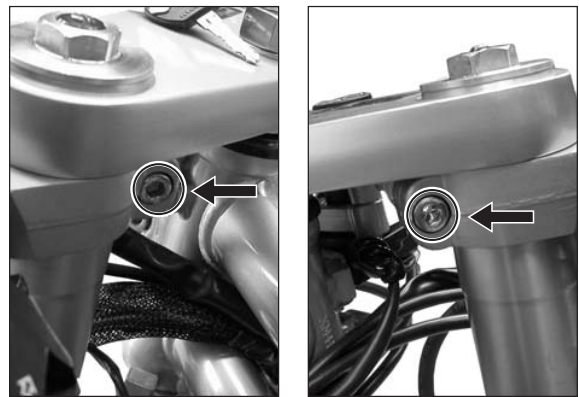

- Loosen the front fork upper clamp bolt, right and left.

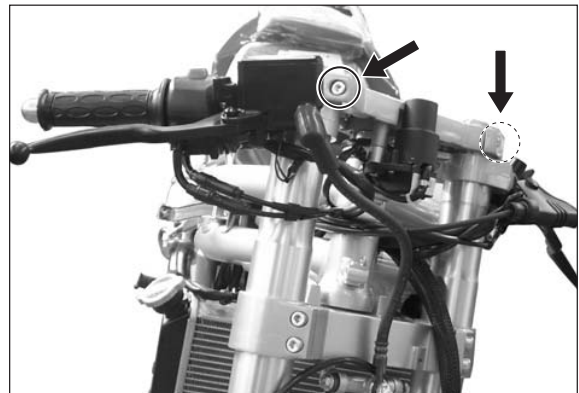

- Remove the steering stem upper bracket by removing the steering stem head nut.

NOTE
<i>Place the rags under the steering stem upper bracket to prevent scratching the body cowling.</i>



- Remove the handlebar holder bolt, right and left.
- Draw out the handlebars to upward.

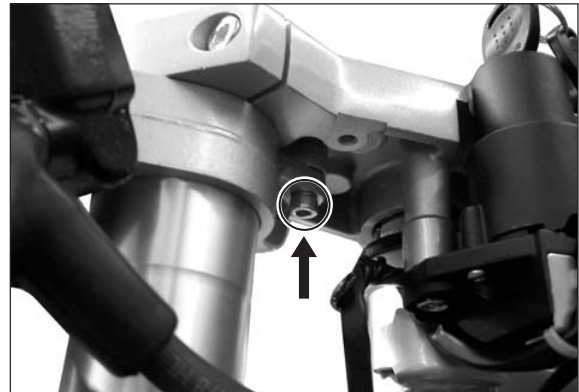

REMOUNTING

Remount the handlebar in the reverse order of removal.
Pay attention to the following point :

- Install the handlebars temporary.
- Install the steering stem upper bracket.
- Tighten the steering stem head nut.

 **Steering stem head nut**
: 80 ~ 100 N \cdot m (8.0 ~ 10.0 kg \cdot m)



- Tighten the front fork upper clamp bolt, right and left.

 **Front fork upper clamp bolts**
: 22 ~ 35 N \cdot m (2.2 ~ 3.5 kg \cdot m)

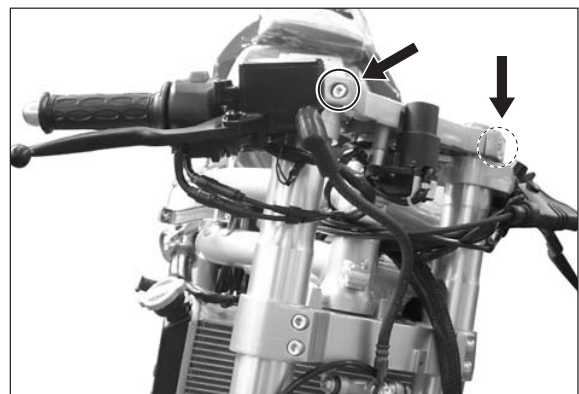

- Tighten the handlebar clamp bolts, right and left.

 **Handlebar clamp bolt**
: 22 ~ 35 N \cdot m (2.2 ~ 3.5 kg \cdot m)

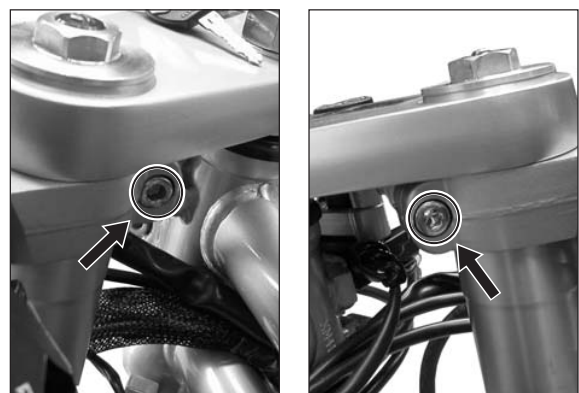

7-14-2 CHASSIS

- When remounting the clutch lever holder, align the holder mating surface (A) with punch mark (B) on the handlebar.

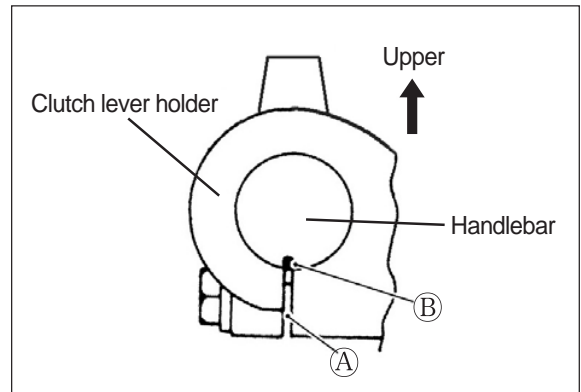

- When remounting the front brake master cylinder onto the handlebar, align the master cylinder holder mating surface (C) with punch mark (D) on the handlebar and tighten the upper clamp bolt first as shown.

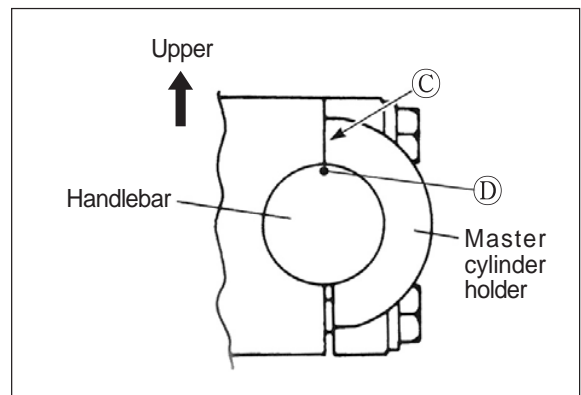

WARNING

Bleed air from the brake fluid circuit after assembling master cylinder.

Refer to the service manual 『Comet 650 (99000-94810)』 page 2 - 17

- Apply SUPER GREASE; A; to the throttle cables.

 SUPER GREASE; A; -

- Install the throttle cable and returning cable to the throttle grip (1), (2).
① : Throttle cable
② : Returning cable

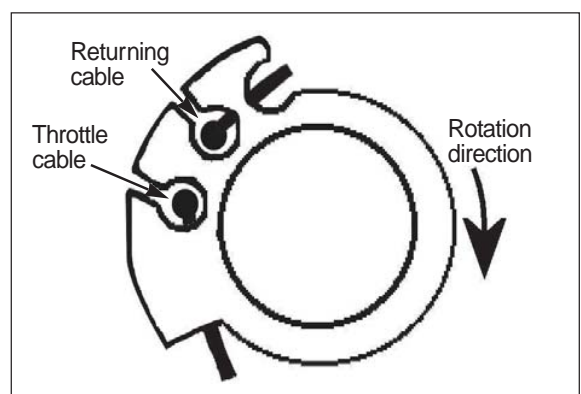
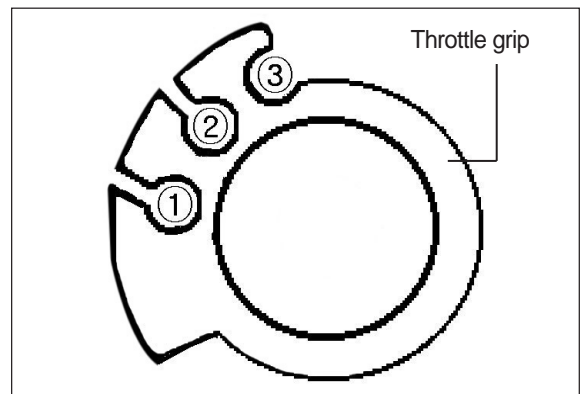

STEERING

⑤ *Comet650S* (Standad type)

☞ Refer to the service manual 『*Comet650* (99000-94810)』 page 7- 23 ~ 25

⑤ *Comet650S* (Sports type) & *Comet650R*

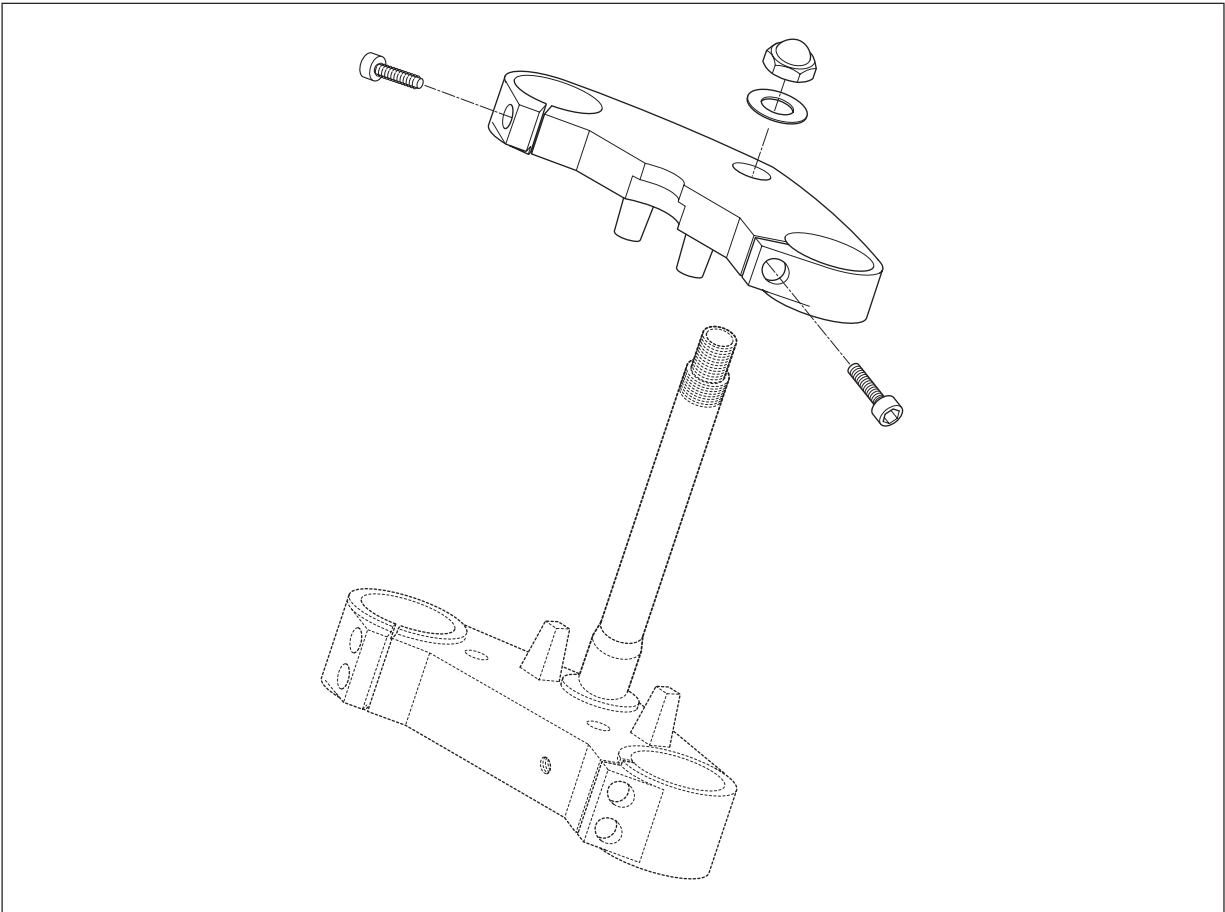

⑤ REMOVAL AND DISASSEMBLY

- Remove the under cowling and body cowling. (*Comet650R*)
(Refer to page 7-1-2 ~ 5)
- Remove the body cowling. (*Comet650S*)
(Refer to page 7-1-4 ~ 5)
- Take off the front wheel.
 - ☞ Refer to the service manual 『*Comet650* (99000-94810)』 page 7-2
- Remove the four bolts and front fender.
- Take off the front fork.
 - ☞ Refer to the service manual 『*Comet650* (99000-94810)』 page 7-16



- Remove the handlebar clamp bolts.
- Remove the steering stem head nut ① and take off the steering stem upper bracket ②.



- Remove the steering stem nut ③ and draw out the steering stem.

 **Clamp wrench : 09940-10122**

- Take off the steering stem lower bracket ④.

CAUTION

Hold the steering stem lower bracket by hand to prevent from falling.

- Remove the upper and lower bearings ⑤.
- Remove the outer race fitted on the steering stem. This can be done with a chisel.

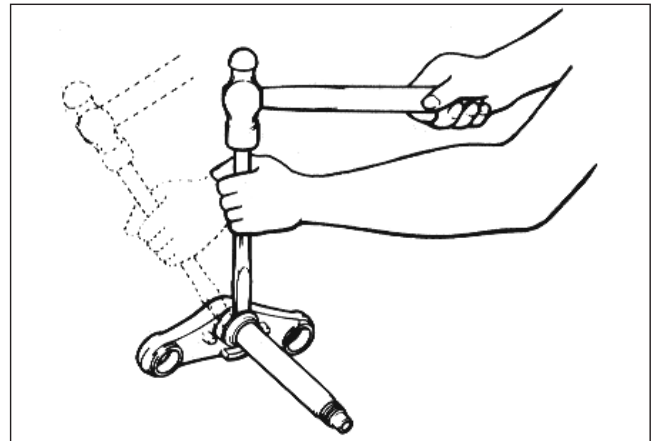
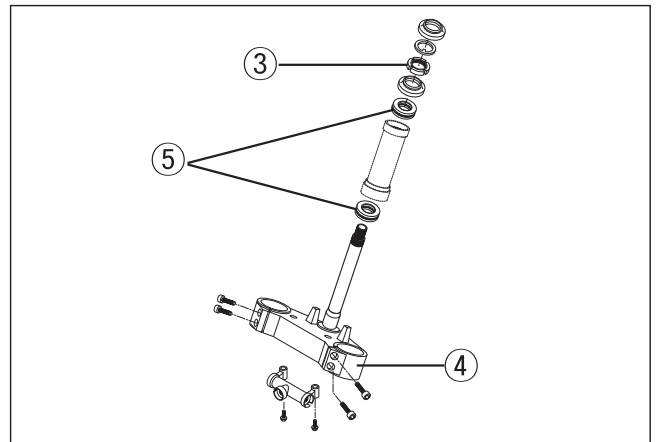

- Draw out the two inner races fitted to the top and bottom ends of the head pipe.

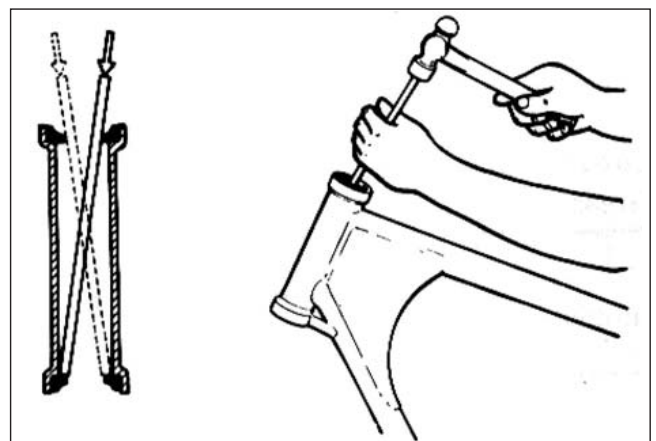

🔍 INSPECTION

Inspect and check the removed parts for the following abnormalities.

- ⚠ Handlebar distortion.
- ⚠ Handlebar clamp wear.
- ⚠ Abnormality operation of bearing.
- ⚠ Worn or damaged races.
- ⚠ Distortion of steering stem.

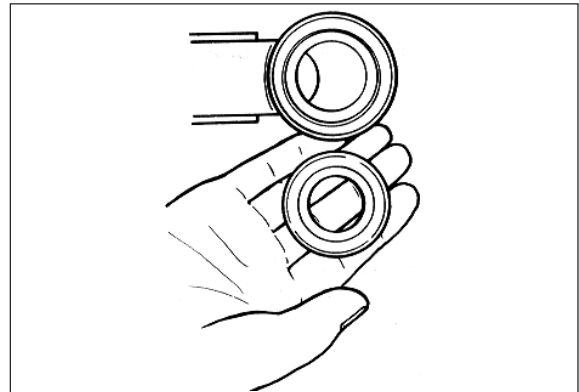

🔧 REASSEMBLY

Reassemble and remount the steering stem in the reverse order of disassembly and removal, and also carry out the following steps :

- Apply SUPER GREASE; A₁ to the upper bearing and lower bearing ①.

 SUPER GREASE; A₁-

- Tighten the steering stem nut ② with the special tool.

 **Clamp wrench : 09940-10122**

 **Steering stem nut**
: 80 ~ 100 N·m (8.0 ~ 10.0 kg·m)

- Turn the steering stem right and left, lock-to-lock, five or six times.

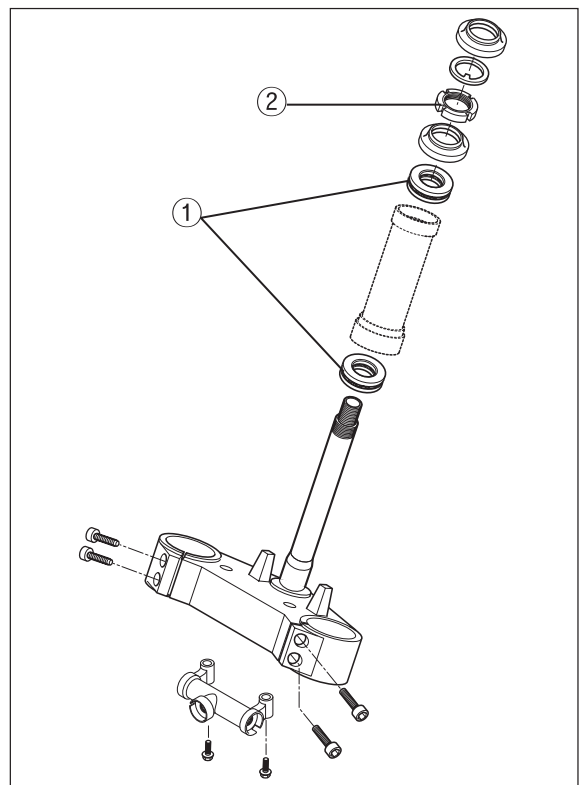

- Tighten the steering stem head nut ③ to the specified torque.

 **Steering stem head nut**
: 80 ~ 100 N·m (8.0 ~ 10.0 kg·m)

⚠ CAUTION

After performing the adjustment and installing the steering stem upper bracket, rock the front wheel assembly forward and backward to ensure that there is no play and that the procedure was accomplished correctly. If play is noticeable, re-adjust the steering stem nut.



7-25-2 CHASSIS

- Tighten the handlebar clamp bolts, right and left.

 **Handlebar clamp bolts**
: 22 ~ 35 N·m (2.2 ~ 3.5 kg·m)



SERVICING INFORMATION

CONTENTS

<i>SERVICE DATA</i>	38(8-20)
<i>WIRE AND CABLE ROUTING</i>	39(8-24-1)
<i>WIRING DIAGRAM</i>	47(8-28)

SERVICE DATA

WATTAGE

Unit : W

ITEM	SPECIFICATION	
Head lamp	HI	H1 : 55W
	LO	H3 : 55W
License plate lamp	5W	
Brake/Tail lamp	21/5W	
Turn signal lamp	Front : 10W×2 / Rear : 10W×2	
Illumination lamp	1.7W×2	
Neutral indicator lamp	VFD	
Turn signal indicator lamp (Right & left)	VFD	
High beam indicator lamp	VFD	
Fuel indicator lamp	VFD	Level type
Coolant temperature indicator lamp	VFD	Level type



CAUTION

Do not use except the specified bulb (Wattage).

NOTE

VFD : Vacuum Fluorescent Display

WIRE AND CABLE ROUTING

SERVICING INFORMATION 8-24-1

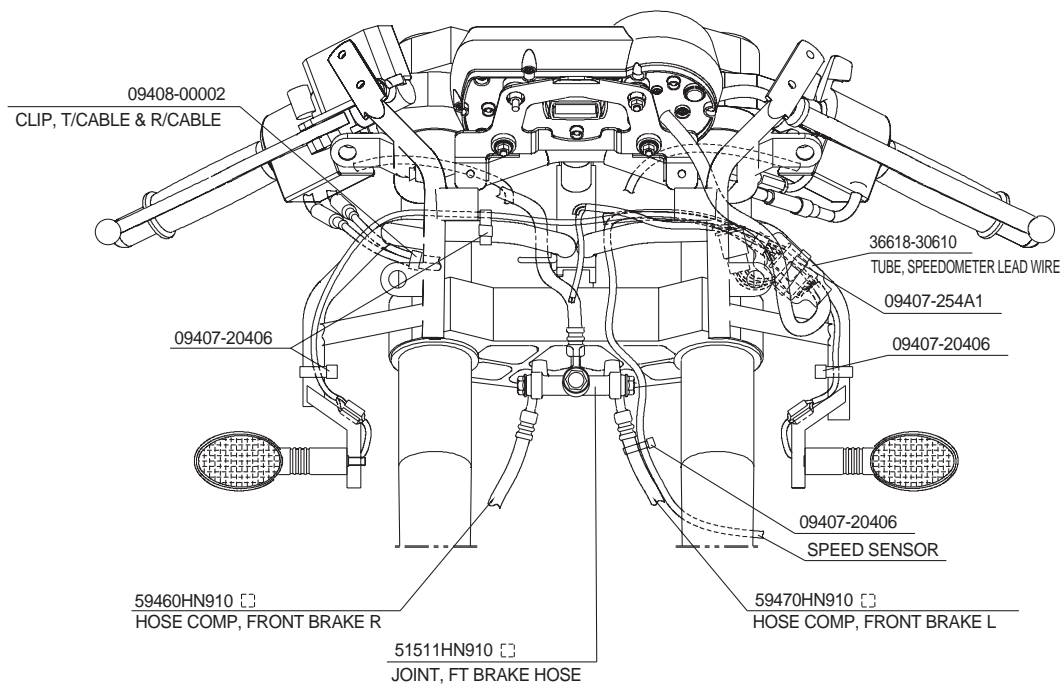

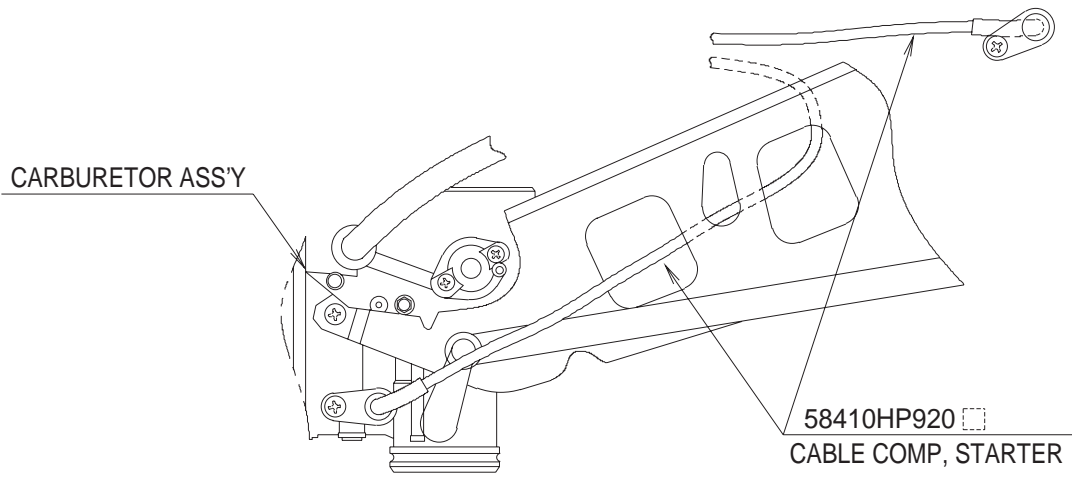

VIEW A

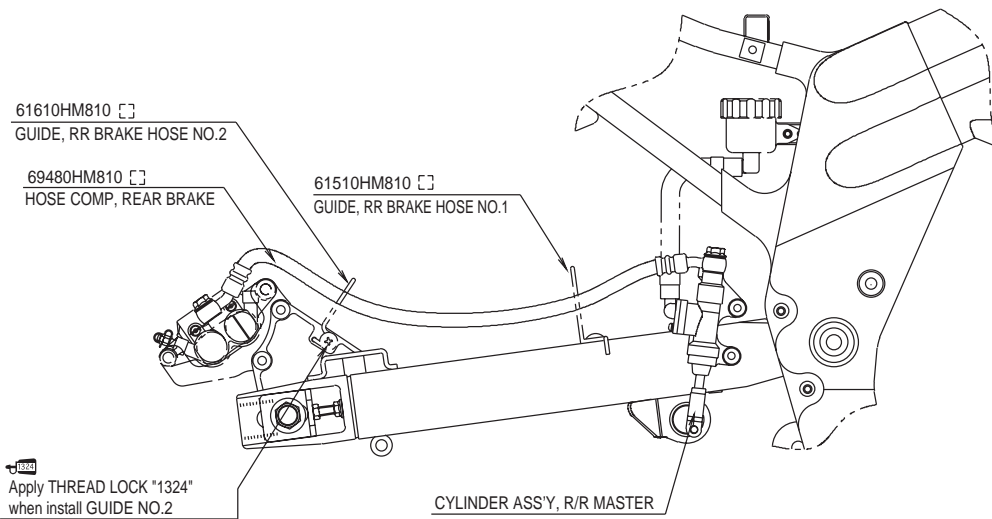

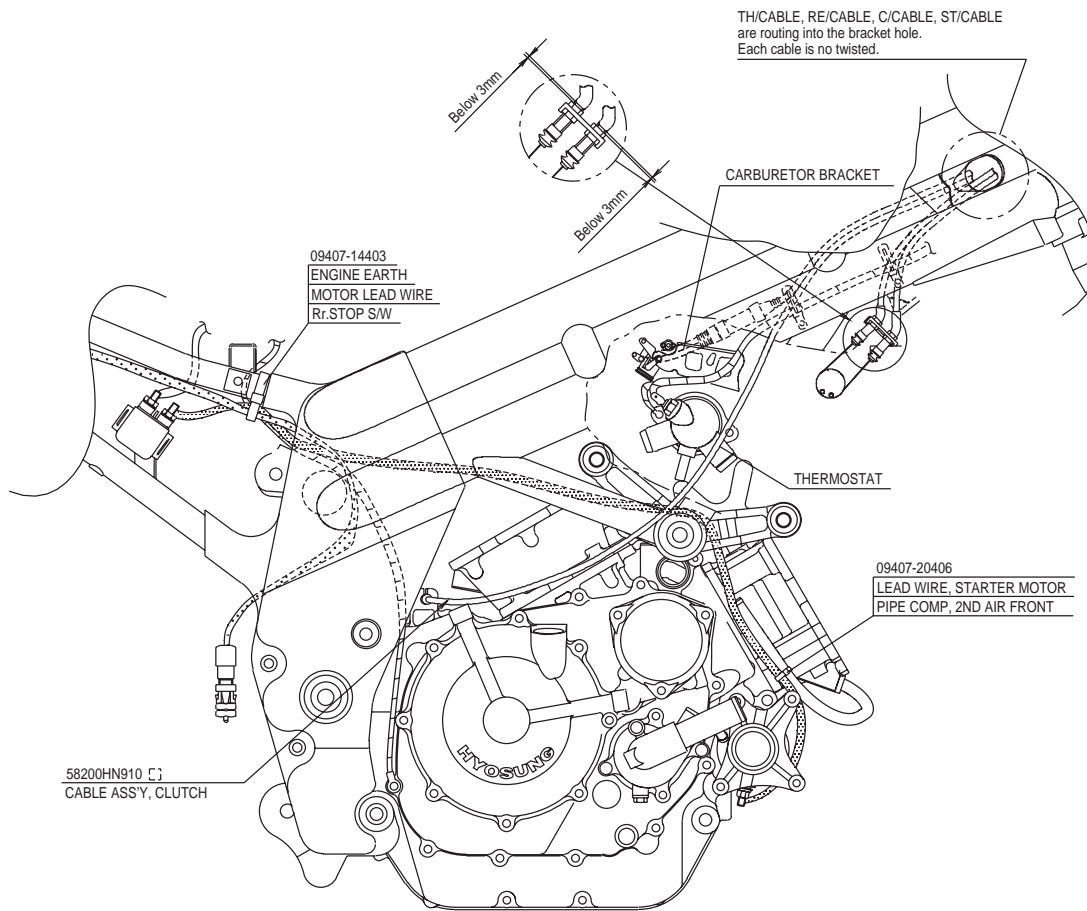

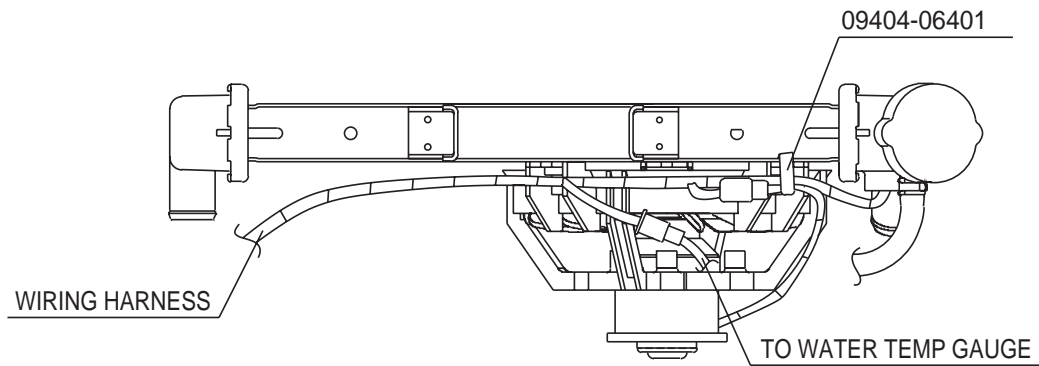

FRONT CYLINDER

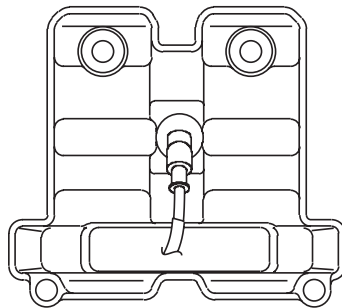

REAR CYLINDER

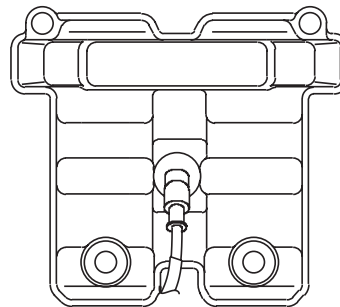

CAUTION FOR HIGHTENTION CORD INSTALLATION DIRECTION

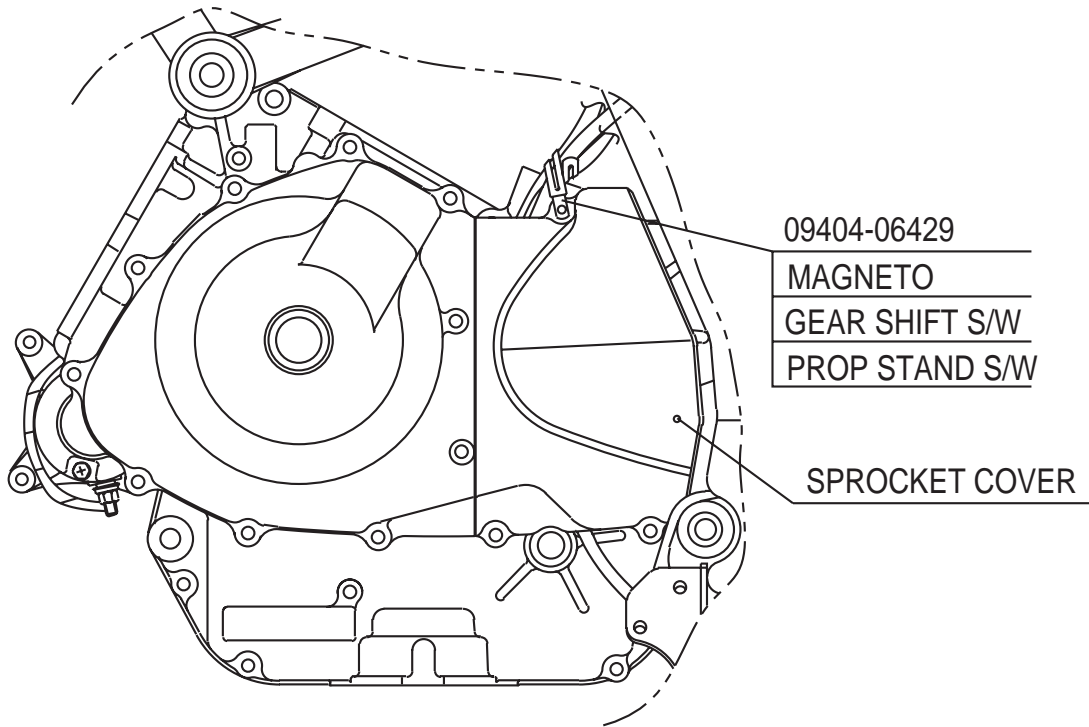

WIRING DIAGRAM

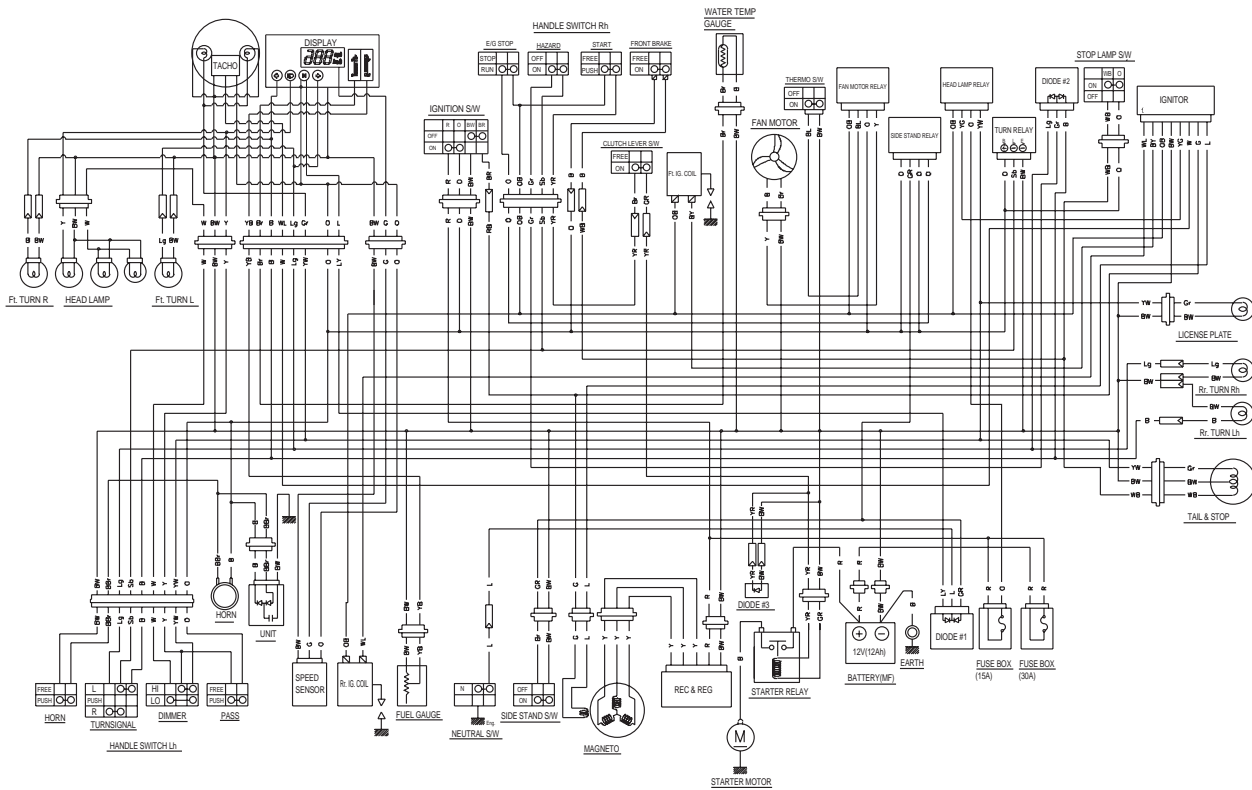

WIRE COLOR

B : Black	Lg : Light green	Y : Yellow	RB : Red with Black tracer
Br : Brown	O : Orange	BG : Black with Green tracer	RW : Red with White tracer
G : Green	R : Red	BW : Black with White tracer	WB : White with Black tracer
Gr : Gray	Sb : Light blue	BR : Black with Red tracer	WR : White with Red tracer
L : Blue	W : White	LW : Blue with White tracer	YB : Yellow with Black tracer



Prepared by

HYOSUNG MOTORS & MACHINERY INC.

1st Ed. APR. 2005.

Manual No. 99000-94910

Printed in Korea